

**Rectangular, Square and  
Circular Steel Hollow Sections**

# Profile

Located at Jamshedpur, Tata Steel Ltd. was established in 1907 and was the first Integrated Steel Plant in India. It commenced its operations in 1911, with a capacity of 1,00,000 tonnes per annum of ingots and expanded to a million tonnes per annum of saleable steel by the mid fifties.

Presently it has an annual capacity of 10 million tonnes at its Jamshedpur Plant. The plant, equipped with the latest steel making facilities such as Basic Oxygen Furnaces, Vacuum Degassing and Continuous Casting Units, presents the very epitome of technological advancement. A whole range of steels addressing the needs of the construction, engineering and automotive sector, testify to Tata Steel's capability in steel making. These products have found acceptance not only in the domestic market but all over the world.



Tata Steel Plant, Jamshedpur

# Contents

Tata Steel - Tubes SBU .....	1
The Process .....	1
Quality Control .....	1
Advantages of Tata Structura Steel Hollow Sections .....	2
Internal Corrosion - A Case Study .....	3
Architectural .....	4
Infrastructural .....	5
Industrial .....	6
General Engineering .....	7
Section Properties - Tata Structura Square Hollow Sections .....	8
Product Range Availability - Tata Structura Square Hollow Sections .....	9
Section Properties - Tata Structura Rectangular Hollow Sections .....	10
Product Range Availability - Tata Structura Rectangular Hollow Sections .....	11
Section Properties - Tata Structura Circular Hollow Sections .....	12
Product Range Availability - Tata Structura Circular Hollow Sections .....	13
General Technical Specifications and Tolerances .....	14
Fabrication and Connection Details .....	15
List of Contacts .....	17

# Tata Steel-Tubes SBU

Tata Steel - Tubes SBU is the outcome of the merger between Indian Tube Company with Tata Steel in 1985. Tubes SBU today is a leading manufacturer of welded pipes in the country having an installed capacity of over 4,50,000 MT per annum.

Currently, Tubes SBU manufactures Structural, Conveyance, Automotive and Boiler Tubes at its plant in Jamshedpur and some external processing agents (EPA).

Tubes SBU manufactures Structural Tubes under the brand name **Tata Structura**. **Tata Structura** is manufactured conforming to **IS:4923** and **IS:1161** standards for square, rectangular and circular sections respectively. **Tata Structura** can be manufactured up to a maximum size of 250X250 mm for square sections, 300X200 mm for rectangular sections and 300 mm NB for circular sections. The thickness can vary from 2 mm to 10 mm. **Tata Structura** has recently forayed into retail space under the initiative **Tata Structura World**, providing consumers with 360 degree solutions right from the design to the fabrication stage. Adding to the product portfolio as well as catering to the changing consumer demands, **Tata Structura** has started manufacturing GP/GI tubes in NB ranging from 20 mm to 50 mm with thickness varying between 1.4 mm to 2 mm.



**Tata Structura** has multiple applications ranging from architectural, industrial, infrastructural, general engineering to power plants, solar power plants, steel industry, railways etc.

## The Process

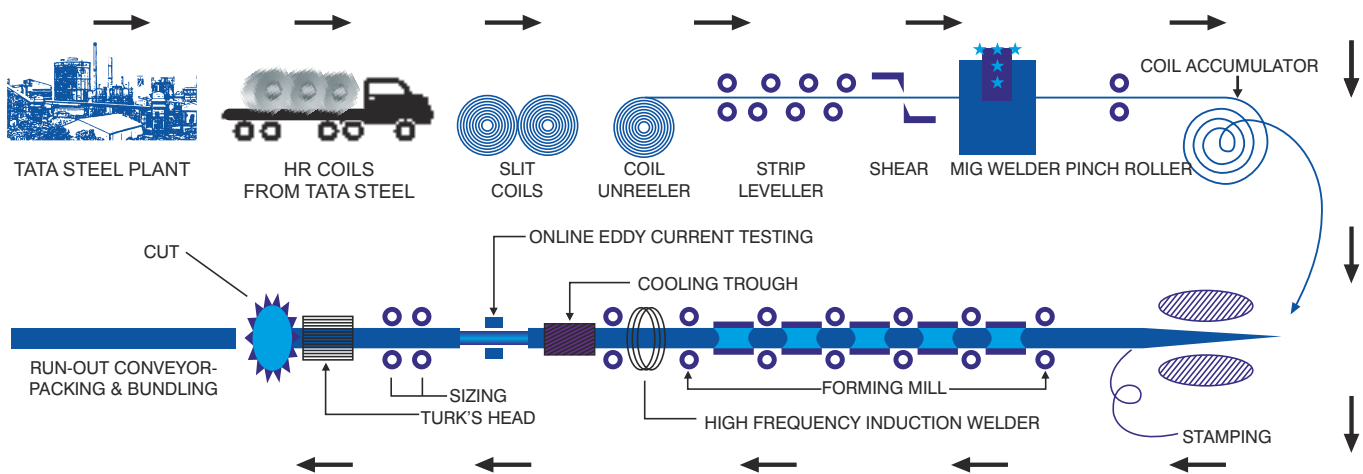

Control Room for On-line Non Destructive Testing

## Quality Control

The quality of our product is controlled during the manufacturing process. It starts with slitting the strip edges, continues with speed, temperature control during the high frequency induction welding and is followed by online non destructive eddy current testing directly after welding. Off-line, drift and flattening tests are conducted. This is all within our ISO 9000 quality management system.



# Advantages of Tata Structura Steel Hollow Sections

- The excellent distribution of material around the axis of these steel hollow sections allows for remarkable strength qualities and thus offers decisive advantages as regards to application technology.
- Their higher strength to weight ratio could result in upto 30% savings in steel.

## The 5Cs of Tata Structura



### Cost Effective

- By virtue of its shape, Hollow sections have high Radius of Gyration and other properties resulting in savings in Material, Transportation and Fabrication cost.
- Less Surface area compared to equivalent conventional sections results in savings in Paint and Labour cost.



### Corrosion Resistant

- Less exposed surface area combined with superior quality raw material results in less corrosion.
- Smooth uniform profiles of sections minimizes dust and moisture accumulation.

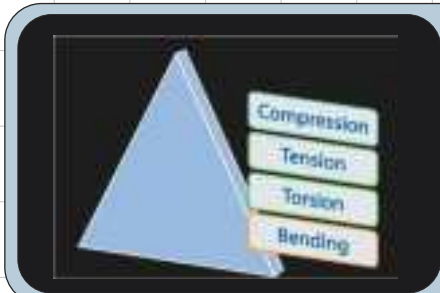

### Concentric Strength

- By virtue of its shape, Hollow sections have high Radius of Gyration resulting in higher concentric strength.
- Due to closeness of the section there will be higher torsional rigidity compared to conventional sections.
- Better lateral stability and lower wind drag.
- Enables weight reduction of upto 30%.



Commonwealth Games Village, Delhi

### Convenience of Fabrication

- Due to less weight and smoother profile, fabrication is easier.
- Also minimum use of gusset plates expedites the fabrication process.



Butterfly Park, Bengaluru

### Creativity

- Due to higher torsional rigidity and better moment resistance on both the axis, bending of hollow section is easier compared to open sections. This gives flexibility to the architects to shape their structures and express their creativity.
- Smooth profile of Tata Structura enhances the aesthetic appeal of the structures.
- Most suitable for usage in exposed environment.

# Internal Corrosion - A Case Study



**Objective:** Identify the possibility of corrosion in the internal surface of steel hollow sections

**Details of the study conducted:**

Two of the original 'Tubewrights' erected in 1954 at Stanford Bridge, Chelsea were replaced in 1975, taken down and the used sections were cut and despatched to the Corby Works of British Steel for examination.

**Sample No. 1** of the 139.7 mm o.d. CHS was cut lengthwise to expose the internal surfaces for examination. Little evidence of internal corrosion was found other than a discolouration of the surface caused by the oxygen and moisture in the entrapped air, much of the original mill scale was still visible. A light rust in the centre of the sample developed after the tube was cut open for examination.

**Sample No. 2** of the 139.7 mm o.d. CHS incorporating an intermediate flanged joint was examined and the condition of the internal flange face, which had been enclosed and thus hermetically sealed by welding to the CHS, was still comparatively bright, with the original marking-off lines clearly visible.

**Outcome & Recommendation:** All the free ends of the steel hollow sections should be properly sealed by welding end plates.

**Source:** The above report is from British Steel Publication No. TD 347/10E/91 titled – CORROSION, THE CASE FOR STRUCTURAL HOLLOW SECTIONS.



Tata Steel, Jamshedpur

## Applications of Tata Structura

The applications of Tata Structura has been classified under the following segments:

- **Architectural**
- **Infrastructural**
- **Industrial**
- **General Engineering**





## Applications

- Shopping Malls
- Canopies/Atrium
- Glass Curtain Wall Frames
- Partition Frames
- Space Frames
- Guard Rails & Staircases

## Attributes

- Lightweight
- Flexible and easy to form shapes
- Smooth surface finish
- Appealing aesthetics
- Contemporary

# Architectural

Edassery Kayal Resorts, Kumarakom



Palakunnu Bhagavathi Temple, Kasargod



Infosys, Pune



The Charkha, Mumbai





Mumbai Airport

# Infrastructural

## Applications

- Airport Terminal Buildings
- Bridges
- Bus Stands
- Sign Supporting Structures
- Pedestrian Walkovers (Footbridge)
- Sports Galleries
- Railways Platforms / Foot Over Bridges

## Attributes

- High strength
- More column free space
- Larger & thicker sections
- Ease of fabrication
- Lightweight



Railway Platform Shed, Krishnanagar



Commonwealth Games Village, Delhi



Footbridge Connector, iGATE Campus





# Industrial

Coal Washery-Talcher, Orissa



Mactech, Baroda



Steel Melting Shop, Jamshedpur



Factory Building, Tata Steel, Jamshedpur

## Applications

- Industrial Sheds
- Trusses, Columns and Purlins
- Material Storage Racks
- Mine Roof Support Systems (cogs, props)
- Pallets
- Pipe Racks
- Conveyor Gantries, Trestles
- Drilling Rigs
- Steel & Power Plants

## Attributes

- High strength to weight ratio
- Cost effective
- Ease of fabrication and erection
- Ease of maintenance
- Free from sharp edges



# General Engineering

## Applications

- Automobile Chassis
- Greenhouse Structures
- Truck & Bus Body Members
- Hoarding Structures
- Amusement Park & Playground Equipment
- Exhibition Stalls
- Scaffolding
- Furniture
- Solar Power Plant Structures

## Attributes

- Lightweight
- Ease of fabrication
- High torsional resistance
- Minimal painting area
- Appealing aesthetics



Solar Power Plant Application



Scaffolding Application



Automobile Chassis Application



Greenhouse Structures

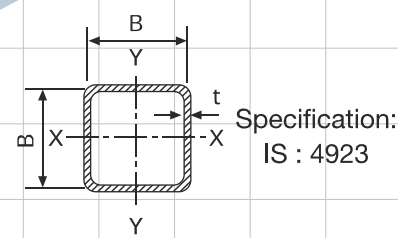

# Section Properties

Properties of Tata Structura (Square Hollow Sections)

YST 310 Grade

SHS B x B mm	Thickness mm	Sec Area A cm <sup>2</sup>	Unit W Kg/m	Moment of Inertia		Radius of Gyration		Elastic Modulus		Torsional Constants		Outer Surface
				I <sub>xx</sub> cm <sup>4</sup>	I <sub>yy</sub> cm <sup>4</sup>	r <sub>xx</sub> cm	r <sub>yy</sub> cm	Z <sub>xx</sub> cm <sup>3</sup>	Z <sub>yy</sub> cm <sup>3</sup>	J cm <sup>4</sup>	B <sup>3</sup> cm <sup>3</sup>	Area per m m <sup>2</sup>
25x25	2.00	1.74	1.36	1.48	1.48	0.92	0.92	1.19	1.19	2.29	1.68	0.090
	2.60	2.16	1.69	1.72	1.72	0.89	0.89	1.38	1.38	2.68	1.92	0.087
	3.20	2.53	1.98	1.89	1.89	0.86	0.86	1.51	1.51	2.96	2.07	0.084
32x32	2.00	2.30	1.80	3.36	3.36	1.21	1.21	2.10	2.10	5.30	3.05	0.118
	2.60	2.88	2.26	4.02	4.02	1.18	1.18	2.51	2.51	6.45	3.63	0.115
	3.20	3.42	2.69	4.54	4.54	1.15	1.15	2.84	2.84	7.41	4.07	0.112
38x38	2.60	3.51	2.75	7.14	7.14	1.43	1.43	3.76	3.76	11.51	5.49	0.139
	3.20	4.19	3.29	8.18	8.18	1.40	1.40	4.30	4.30	13.45	6.28	0.136
	4.00	5.03	3.95	9.26	9.26	1.36	1.36	4.87	4.87	15.67	7.12	0.131
40x40	2.60	3.72	2.92	8.45	8.45	1.51	1.51	4.22	4.22	13.63	6.20	0.147
	3.20	4.45	3.49	9.72	9.72	1.48	1.48	4.86	4.86	16.00	7.12	0.144
	4.00	5.35	4.20	11.07	11.07	1.44	1.44	5.54	5.54	18.75	8.12	0.139
50x50	2.60	4.76	3.74	17.47	17.47	1.92	1.92	6.99	6.99	28.53	10.37	0.187
	2.90	5.25	4.12	18.99	18.99	1.90	1.90	7.60	7.60	31.15	11.23	0.185
	3.60	6.35	4.98	22.15	22.15	1.87	1.87	8.86	8.86	36.58	12.98	0.181
	4.50	7.67	6.02	25.50	25.50	1.82	1.82	10.20	10.20	41.99	14.68	0.177
60x60	2.60	5.80	4.55	31.33	31.33	2.33	2.33	10.44	10.44	50.08	15.52	0.227
	3.20	7.01	5.50	36.94	36.94	2.30	2.30	12.31	12.31	60.02	18.31	0.224
	4.00	8.55	6.71	43.55	43.55	2.26	2.26	14.52	14.52	72.41	21.62	0.219
	4.80	10.01	7.85	49.22	49.22	2.22	2.22	16.41	16.41	83.86	24.51	0.215
72x72	3.20	8.54	6.71	66.32	66.32	2.79	2.79	18.42	18.42	106.81	27.47	0.272
	4.00	10.47	8.22	79.03	79.03	2.75	2.75	21.95	21.95	129.85	32.78	0.267
	4.80	12.31	9.66	90.31	90.31	2.71	2.71	25.09	25.09	151.55	37.55	0.263
80x80	3.20	9.57	7.51	92.71	92.71	3.11	3.11	23.18	23.18	148.55	34.60	0.304
	4.00	11.75	9.22	111.04	111.04	3.07	3.07	27.76	27.76	181.22	41.49	0.299
	4.80	13.85	10.87	127.58	127.58	3.04	3.04	31.89	31.89	212.26	47.77	0.295
91.5x91.5	3.60	12.32	9.67	156.49	156.49	3.56	3.56	34.21	34.21	251.17	51.14	0.347
	4.50	15.14	11.88	187.57	187.57	3.52	3.52	41.00	41.00	306.78	61.40	0.343
	5.40	17.85	14.01	215.68	215.68	3.48	3.48	47.14	47.14	359.76	70.77	0.338
100x100	4.00	14.95	11.73	226.35	226.35	3.89	3.89	45.27	45.27	364.75	67.50	0.379
	5.00	18.36	14.41	271.10	271.10	3.84	3.84	54.22	54.22	441.84	80.54	0.374
	6.00	21.63	16.98	311.47	311.47	3.79	3.79	62.29	62.29	511.80	92.06	0.369
113.5x113.5	4.80	20.28	15.92	393.30	393.30	4.40	4.40	69.30	69.30	637.45	103.89	0.429
	5.40	22.60	17.74	432.58	432.58	4.38	4.38	76.23	76.23	708.69	114.41	0.426
132x132	4.80	23.83	18.71	634.39	634.39	5.16	5.16	96.12	96.12	1018.30	144.11	0.503
	5.40	26.60	20.88	700.11	700.11	5.13	5.13	106.08	106.08	1134.25	159.18	0.500
150x150	4.00	22.95	18.01	807.82	807.82	5.93	5.93	107.71	107.71	1273.46	161.38	0.579
	5.00	28.36	22.26	982.12	982.12	5.89	5.89	130.95	130.95	1569.09	196.38	0.574
	6.00	33.63	26.40	1145.91	1145.91	5.84	5.84	152.79	152.79	1856.18	229.44	0.569
	8.00	43.79	34.38	1443.00	1443.00	5.74	5.74	192.40	192.40	2405.78	290.12	0.559
180x180	4.00	27.75	21.78	1421.74	1421.74	7.16	7.16	157.97	157.97	2224.31	236.76	0.699
	5.00	34.36	26.97	1736.87	1736.87	7.11	7.11	192.99	192.99	2747.93	289.40	0.694
	6.00	40.83	32.05	2036.52	2036.52	7.06	7.06	226.28	226.28	3259.23	339.65	0.689
	8.00	53.39	41.91	2590.73	2590.73	6.97	6.97	287.86	287.86	4246.16	433.32	0.679
220x220	5.00	42.36	33.25	3238.12	3238.12	8.74	8.74	294.37	294.37	5083.17	440.67	0.854
	6.00	50.43	39.59	3813.36	3813.36	8.70	8.70	346.67	346.67	6034.53	520.18	0.849
	8.00	66.19	51.96	4894.99	4894.99	8.60	8.60	445.00	445.00	7897.48	668.99	0.839
	10.00	81.43	63.92	5887.19	5887.19	8.50	8.50	535.20	535.20	9549.15	796.48	0.829
250x250	6.00	57.63	45.24	5672.00	5672.00	9.92	9.92	453.76	453.76	8920.44	680.77	0.969
	8.00	75.79	59.50	7315.65	7315.65	9.82	9.82	585.25	585.25	11702.07	879.31	0.959
	10.00	93.43	73.34	8842.29	8842.29	9.73	9.73	707.38	707.38	14248.15	1054.68	0.949

Orange box sizes are for large diameter sections



# Product Range Availability

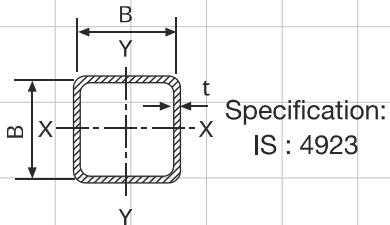

## Product Range : Square Hollow Sections (SHS)

Section Size	Tube Dimension (mm)		Wall Thickness (mm) = t												
	B	B	2.0	2.6	2.9	3.2	3.6	4.0	4.5	4.8	5.0	5.4	6.0	8.0	10.0
25	25														
32	32														
38	38														
40	40														
50	50														
60	60														
72	72														
80	80														
91.5	91.5														
100	100														
113.5	113.5														
132	132														
150	150														
180	180														
220	220														
250	250														

Orange box sizes are for large diameter sections

 Indicates presently rolled sections

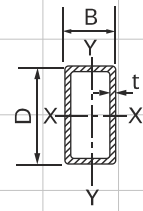

Specification:  
IS : 4923

# Section Properties

Properties of Tata Structura (Rectangular Hollow Sections)

YST 310 Grade

RHS DxB mm	Thickness mm	Sec Area A cm <sup>2</sup>	Unit W Kg/m	Moment of Inertia		Radius of Gyration		Elastic Modulus		Torsional Constants		Outer Surface
				I <sub>xx</sub> cm <sup>4</sup>	I <sub>yy</sub> cm <sup>4</sup>	r <sub>xx</sub> cm	r <sub>yy</sub> cm	Z <sub>xx</sub> cm <sup>3</sup>	Z <sub>yy</sub> cm <sup>3</sup>	J cm <sup>4</sup>	B cm <sup>3</sup>	Area per m m <sup>2</sup>
50x25	2.00	2.74	2.15	8.38	2.81	1.75	1.01	3.35	2.25	6.79	3.79	0.142
	2.60	3.46	2.71	10.16	3.36	1.71	0.99	4.06	2.69	8.27	4.53	0.137
	3.20	4.13	3.24	11.63	3.80	1.68	0.96	4.65	3.04	9.52	5.12	0.134
	4.00	4.95	3.88	13.13	4.23	1.63	0.92	5.25	3.38	10.86	5.69	0.129
60x40	2.60	4.76	3.73	22.76	12.09	2.19	1.59	7.59	6.05	25.59	9.83	0.187
	2.90	5.25	4.12	24.74	13.11	2.17	1.58	8.25	6.56	28.02	10.66	0.185
	3.60	6.35	4.98	28.90	15.23	2.13	1.55	9.63	7.62	33.30	12.41	0.181
	4.50	7.67	6.02	33.31	17.44	2.08	1.51	11.10	8.72	39.34	14.29	0.177
66x33	2.60	4.70	3.69	25.15	8.43	2.31	1.34	7.62	5.11	20.75	8.71	0.185
	2.90	5.19	4.07	27.33	9.12	2.29	1.33	8.28	5.53	22.65	9.43	0.183
	3.60	6.28	4.93	31.87	10.52	2.25	1.29	9.66	6.37	26.71	10.90	0.179
	4.50	7.58	5.95	36.64	11.93	2.20	1.25	11.10	7.23	31.21	12.43	0.175
80x40	2.60	5.80	4.55	46.58	15.74	2.84	1.65	11.65	7.87	38.50	13.46	0.227
	3.20	7.01	5.50	54.94	18.41	2.80	1.62	13.74	9.21	45.83	15.78	0.224
	4.00	8.55	6.71	64.79	21.49	2.75	1.59	16.20	10.74	54.77	18.49	0.219
	4.80	10.01	7.85	73.22	24.03	2.71	1.55	18.30	12.02	62.81	20.79	0.215
96x48	3.20	8.54	6.71	98.61	33.28	3.40	1.97	20.54	13.87	82.13	23.82	0.272
	4.00	10.47	8.22	117.54	39.32	3.35	1.94	24.49	16.38	99.11	28.24	0.267
	4.80	12.31	9.66	134.35	44.55	3.30	1.90	27.99	18.56	114.80	32.14	0.263
122x61	3.60	12.32	9.67	232.61	78.83	4.34	2.53	38.13	25.84	193.91	44.50	0.347
	4.50	15.14	11.88	278.94	93.78	4.29	2.49	45.73	30.75	235.39	53.13	0.343
	5.40	17.85	14.01	320.83	107.03	4.24	2.45	52.60	35.09	274.29	60.89	0.338
145x82	4.80	20.28	15.92	555.16	228.50	5.23	3.36	76.57	55.73	534.27	94.45	0.429
	5.40	22.60	17.74	610.85	250.59	5.20	3.33	84.26	61.12	592.70	103.81	0.426
172x92	4.80	23.83	18.71	917.13	346.91	6.20	3.82	106.64	75.41	826.04	128.85	0.503
	5.40	26.59	20.88	1012.47	381.74	6.17	3.79	117.73	82.99	918.10	142.04	0.500
200x100	4.00	22.95	18.01	1199.71	410.78	7.23	4.23	119.97	82.16	991.47	141.46	0.579
	5.00	28.36	22.26	1459.25	496.94	7.17	4.19	145.93	99.39	1216.96	171.53	0.574
	6.00	33.63	26.40	1703.31	576.91	7.12	4.14	170.33	115.38	1434.03	199.68	0.569
	8.00	43.79	34.38	2146.21	719.19	7.00	4.05	214.62	143.84	1843.86	250.68	0.559
240x120	4.00	27.75	21.78	2110.72	725.35	8.72	5.11	175.89	120.89	1736.39	208.03	0.699
	5.00	34.36	26.97	2579.67	882.47	8.67	5.07	214.97	147.08	2138.48	253.55	0.694
	6.00	40.83	32.05	3025.91	1030.45	8.61	5.02	252.16	171.74	2528.39	296.70	0.689
	8.00	53.39	41.91	3851.84	1299.95	8.49	4.93	320.99	216.66	3272.90	376.29	0.679
300x150	6.00	51.63	40.53	6073.51	2079.57	10.85	6.35	404.90	277.28	5034.64	478.20	0.869
	8.00	67.79	53.22	7807.95	2654.12	10.73	6.26	520.53	353.88	6559.05	612.64	0.859
	10.00	83.43	65.49	9403.90	3173.71	10.62	6.17	626.93	423.16	8011.67	736.01	0.848
300x200	6.00	57.63	45.24	7370.23	3962.19	11.31	8.29	491.35	396.22	8186.02	650.85	0.969
	8.00	75.79	59.50	9513.66	5097.04	11.20	8.20	634.24	509.70	10722.83	839.51	0.959
	10.00	93.43	73.34	11507.24	6144.30	11.10	8.11	767.15	614.43	13169.70	1015.43	0.948

Orange box sizes are for large diameter sections



# Product Range Availability

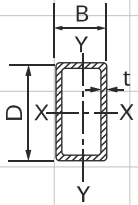

Specification:  
IS : 4923

## Product Range : Rectangular Hollow Sections (RHS)

Section Size	Tube Dimension (mm)		Wall Thickness (mm) = t												
	D	B	2.0	2.6	2.9	3.2	3.6	4.0	4.5	4.8	5.0	5.4	6.0	8.0	10.0
	50	25	■	■		■		■							
	60	40		■	■		■		■						
	66	33		■	■		■		■						
	80	40		■		■		■		■					
	96	48				■		■		■					
	122	61					■		■			■			
	145	82							■			■			
	172	92							■			■			
	200	100						■			■		■	■	
	240	120						■			■		■	■	
	300	150											■	■	■
	300	200											■	■	■

Orange box sizes are for large diameter sections

■ Indicates presently rolled sections

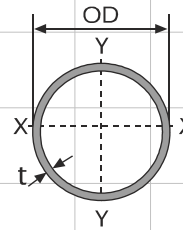

Specification:  
IS : 1161

# Section Properties

Properties of Tata Structura (Circular Hollow Sections)

YST 310 Grade

Nominal Bore	Outside Diameter	Thickness	Weight	Area of Cross Section	Outer Surface Area/m	Moment of Inertia	Section Modulus	Radius of Gyration
mm	mm	mm	kg/m	cm <sup>2</sup>	cm <sup>2</sup> /m	cm <sup>4</sup>	cm <sup>3</sup>	cm
15	21.3	2.00	0.95	1.21	669	0.57	0.54	0.69
		2.60	1.21	1.53		0.69	0.64	0.66
		3.20	1.44	1.82		0.75	0.70	0.65
20	26.9	2.30	1.38	1.78	845	1.36	1.01	0.87
		2.60	1.56	1.98		1.48	1.10	0.86
		3.20	1.87	2.38		1.70	1.26	0.84
25	33.7	2.60	1.98	2.54	1059	3.09	1.83	1.10
		3.20	2.41	3.06		3.61	2.14	1.08
		4.00	2.93	3.73		4.19	2.48	1.05
32	42.4	2.60	2.54	3.25	1332	6.47	3.05	1.41
		3.20	3.01	3.94		7.62	3.59	1.39
		4.00	3.79	4.82		8.99	4.24	1.36
40	48.3	2.90	3.23	4.13	1517	10.70	4.43	1.61
		3.20	3.56	4.53		11.59	4.80	1.59
		4.00	4.37	5.56		13.77	5.70	1.57
50	60.3	2.90	4.08	5.23	1895	21.59	7.16	2.03
		3.60	5.03	6.41		25.88	8.59	2.00
		4.50	6.19	7.88		30.90	10.20	1.98
65	76.1	3.20	5.71	7.32	2391	48.79	12.82	2.58
		3.60	6.42	8.20		54.02	14.20	2.57
		4.50	7.93	10.10		65.12	17.10	2.54
80	88.9	3.20	6.72	8.61	2793	79.23	17.82	3.03
		4.00	8.36	10.70		96.36	21.68	3.00
		4.80	9.90	12.70		112.52	25.31	2.98
100	114.3	3.60	9.75	12.50	3591	192.03	33.60	3.92
		4.50	12.20	15.50		234.30	41.00	3.89
		5.40	14.50	18.50		274.50	48.00	3.85
125	139.7	4.50	15.00	19.10	4389	437.20	62.60	4.78
		4.80	15.90	20.30		463.44	66.35	4.77
		5.40	17.90	22.80		514.50	73.70	4.75
150	165.1	4.50	17.80	22.70	5187	732.60	88.74	5.68
		4.80	18.90	24.20		777.32	94.16	5.67
		5.40	21.30	27.10		864.70	105.00	5.65
200	219.1	4.80	25.38	32.33	6886	1856.78	169.49	7.58
		6.00	31.51	40.17		2281.95	208.30	7.54
		8.00	41.67	53.08		2960.82	270.27	7.47
		10.00	51.59	65.72		3599.89	328.61	7.40
250	273	6.00	39.51	50.30	8580	4487.08	328.72	9.44
		8.00	52.30	66.63		5854.07	428.87	9.37
		10.00	64.89	82.66		7156.97	524.32	9.31
300	323.9	6.30	49.36	62.88	10180	7932.09	489.79	11.23
		8.00	62.35	79.43		9914.07	612.17	11.17
		10.00	77.44	98.65		12163.24	751.05	11.10

Orange box sizes are for large diameter sections



# Product Range Availability

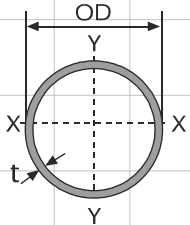

Specification:  
IS : 1161

## Product Range : Circular Hollow Sections (CHS)

	Tube Dimension (mm)		Wall Thickness (mm) = t															
	NB	OD	2.0	2.3	2.6	2.9	3.2	3.6	4.0	4.5	4.8	5.0	5.4	6.0	6.3	8.0	10.0	
Nominal Bore/Outside Diameter	15	21.3	■		■		■											
	20	26.9		■	■		■											
	25	33.7			■		■		■									
	32	42.4			■		■		■									
	40	48.3				■	■		■									
	50	60.3				■		■		■								
	65	76.1					■	■		■								
	80	88.9					■		■		■							
	100	114.3						■		■			■					
	125	139.7							■	■			■					
	150	165.1								■	■		■					
	200	219.1									■			■		■	■	■
	250	273												■		■	■	■
	300	323.9													■	■	■	■

Orange box sizes are for large diameter sections



Indicates presently rolled sections

# General Technical Specifications and Tolerances

## PERMISSIBLE AXIAL COMPRESSIVE STRESS (Yst 310 Grade)

1/r	10	20	30	40	50	60	70	80	90	100	110	120	130	140	150	160	170	180	190	200	210	220	230	240	250	300	350
Ac	186	183	178	169	157	143	128	113	99	87	77	67	60	53	47	42	38	34	31	28	26	23	22	20	18	13	10

\*Source: IS Standards

## OTHER ALLOWABLE STRESS VALUES (IN Mpa)

Steel Grade	Minimum Yield Stress	Minimum UTS	Axial Stress in Tension	Bending Stress In Ten. Or Compn.	Shear Stress	Bearing Stress	Equivalent Stress
Yst 310	310	450	186	205	140	232	279

\*Source: IS Standards

Section Type	Grade	Mechanical Properties				Dimensional Tolerance					
		YST MPa	UTS MPa	% of Elongation		Outside dimension	Thickness	Squareness	Corner radius	Weight	
				< 25.4 mm	> 25.4 mm					Individual Lengths	On lot of 10 MT
RHS/SHS IS : 4923	YST 210	210	330	12	20	+/-1% with a minimum of +/-0.50 mm	+/-10%	90 deg. +/-2 deg.	3t max	10% -8%	+/-7.5%
	YST 240	240	410	10	15						
	<b>YST 310</b>	<b>310</b>	<b>450</b>	<b>8</b>	<b>10</b>						
CHS IS : 1161	YST 210	210	330	12	20	OD upto and incl 48.3+0.4/-0.8mm. Over 48.3 mm +/-1.0%	+ no limit -10%	NA	NA	L +10%, -8%	L +/-5%
	YST 240	240	410	12	17					M & H +/-10%	M & H +/-7.5%
	<b>YST 310</b>	<b>310</b>	<b>450</b>	<b>12</b>	<b>14</b>						

\* YST 210 and YST 240 are also manufactured

\* Galvanized sections can also be manufactured

<b>Length</b>	6.0 m ± 0.05 m Customized length ranging from 6 m to 11 m may be supplied.
<b>Straightness</b>	Minimum 1 : 200 <sup>th</sup> of any length measured along the centre line (mill straightened condition) unless otherwise specifically arranged.
<b>Twist Tolerance</b>	Maximum 2 mm ± 0.05 mm/m length-measured relative vertical shift of any adjacent corner of the section, measured by keeping one side on flat surface.
<b>End Finish</b>	Plain ended-Mechanically sheared, mill-cut finish without further machining.
<b>Surface Finish / Chemical Properties</b>	Black without any surface treatment of oiling or varnishing.
<b>Raw Material</b>	Sulphur content : 0.05% max, phosphorus content : 0.05% max, equivalent carbon percentage well within specified weldability limits with matching physical properties. For corrosion resistant steel in Cu-bearing variety, refer to the WRS section of this brochure.
<b>Weldability</b>	Tata Structura Steel Hollow Sections are weldable with standard M.S. Electrodes without any pre-heating.
<b>Packing</b>	Bundled by sealing metal strap and each bundle is labelled for size, measurement, lot number etc. Approximate weight of each bundle is 1.5 Mt (+/-500 kg).
<b>Identification</b>	Marking of 'TATA STRUCTURA' emblem on surface, punched/stenciled/sticker pasted, on all Steel Hollow Sections. Standard BIS mark is also put on the sections.
<b>Note</b>	Tata Structura Hollow Sections in customized size, grade, length, surface finish and end finish may be delivered as per agreed supply conditions.

\*Conditions apply.

# Fabrication and Connection Details

## OVERLAP JOINTS

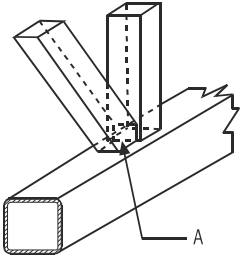

The weld seam 'A' can be omitted without affecting the behaviour of the joint.

## POSSIBLE REINFORCEMENTS

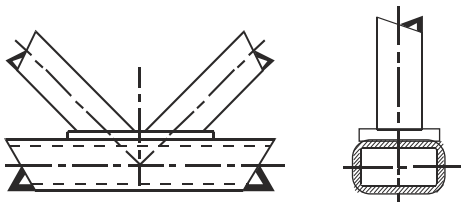

In certain cases reinforced joints are preferred for improved joint rigidity.

## GAP JOINTS

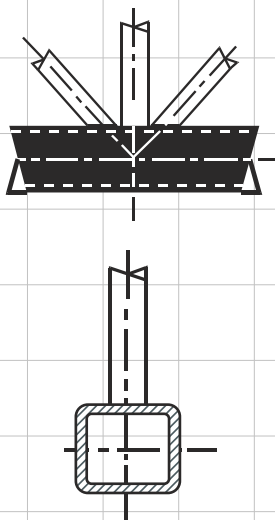

This arrangement is often the simplest and most economical and the joints are sufficiently strong. Joining member alignments should be at  $> 30^\circ$  with respect to the other.

## Jointing : Workshop & Site Practice

### CUTTING

Tata Structura Steel Hollow Sections can be cut:

- By means of a heavy duty circular/hand saw
- By flame cutting: either manual or automatic

- The path of the cut can be marked directly on the surface of the section or on a template after shop layout
- For section thicknesses of 5 mm and above, edges may be chamfered for proper welding penetration

### BENDING

- Axial cold bending of Tata Structura Steel Hollow Sections is possible by using an internal mandrel and the roller must be adapted to the shape and size of the section
- Three roll bending machine may be adapted - bend by slow multiple pass, through trial and error method
- Thicker or larger sections are recommended to be preheated in a normalising furnace before bending in hot condition for better formation

## Jointing : Workshop & Site Practice

### WELDING

Technique in principle is similar for that of conventional sections. Follow relevant BIS code of practice and design conditions.

- **Electrodes:** Low hydrogen electrodes are suggested for use.
- **Butt welds:** The throat thickness of the seam:  
a) Wall thickness of the section when joining members are of equal thickness, b) Wall thickness of thinner section, if thicknesses are different. Backing strip may be provided to ensure total root penetration in case of thicker section design size.
- **Fillet welds:** Various types may be provided. Size of the fillet is guided by the throat thickness as explained above.
- **NOTE:** All free ends of Tata Structure Steel Hollow Sections should be sealed properly by welding, to prevent internal corrosion.
- Normal M. S. electrodes of reputed brands are recommended. Moisture from electrode should be removed by baking before welding.
- **Sequence:** Edges are to be tack welded to maintain uniform gap during welding to minimise residual stress:
  - Transverse weld before longitudinal one
  - Fillet weld following butt weld
  - Starting from inside to outwards.



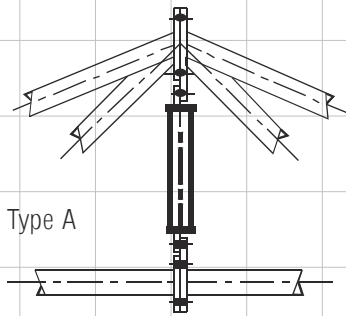

Type A

## BOLTED RIDGE DETAILS & TIE CONNECTIONS

Bolted connections as shown (Type A & Type B) are adopted by using single or double sag ties respectively.

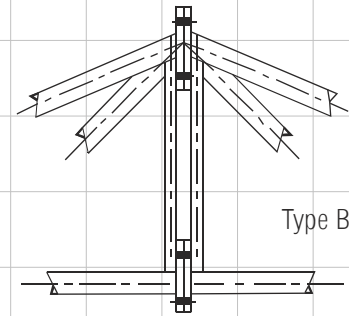

Type B

## TYPICAL SPLICING DETAIL

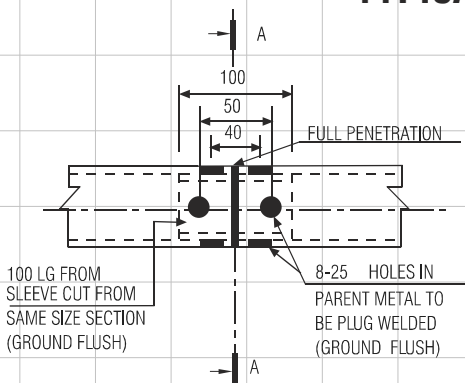

ANGLE CUT FROM  
SAME SIZE SECTION  
TO FIT IN **TATA STRUCTURA**  
**RECTANGULAR & SQUARE**  
**STEEL HOLLOW SECTIONS**

**SEC - A - A**

The internal backing sleeve fulfils two functions; it facilitates the proper alignment of the parts and acts as backing strip for butt weld.

For more technical information, visit our website [www.tatastructura.com](http://www.tatastructura.com) or contact us for Designer Handbook.

## Joining : Workshop & Site Practice

### CORRECTING DISTORTIONS

Post weld distortions, despite precautions, can be corrected by cold bending, hammering of the welds or by applying controlled local compensating heating on opposite sides. It is imperative to avoid excessive thermo-mechanical operation.

### BOLTED/RIVETED CONNECTIONS

- Fasteners should conform to relevant BIS specifications and arrangements should be adequate to withstand combination of design loads at joints and to facilitate ease of fixing,
- As internal surfaces of Tata Structura Steel Hollow Sections are inaccessible, they are adaptable to:
  - Special structural fittings for indirect external bolting
  - Blind bolts
  - Self threading bolts, etc.

### ERECTION

- In principle similar techniques are adopted as those for conventional section assemblies.  
For hoisting and handling no additional stiffeners are required due to high torsional rigidity of Tata Structura Steel Hollow Sections.

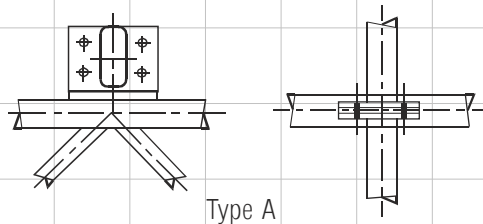

Type A

## PURLIN CONNECTIONS

Purlin becomes very efficient with Tata Structura Rectangular & Square Steel Hollow Sections because of its lateral rigidity to avoid intermediate sag rods. The connection shown (Type A & Type B) can provide end - fixity.

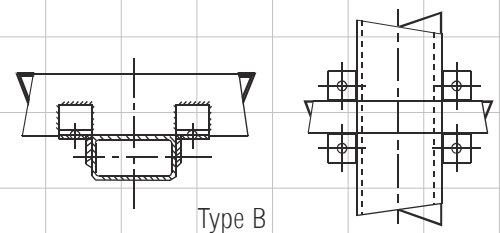

Type B

# List of Contacts

## WORKS

Burma Mines, Jamshedpur-831 007  
Telephone: 0657 2270561, Fax: 0657 2270304

## MARKETING HEADQUARTERS

Tata Centre, 43, J. L. Nehru Road, Kolkata-700 071  
Telephone: 033 2288-7051/9251/8106, Fax: 033 2288-6996

### North Zone

#### New Delhi

Tata Steel - Tubes SBU,  
Marketing & Sales Division  
Jeevan Tara Building, 1st Floor,  
5, Sansad Marg, New Delhi-110 001  
Tel: 0112374 8294/8169  
Fax: 0112334 3196

#### Faridabad

Tata Steel - Tubes SBU,  
Marketing & Sales Division  
C/o-Fast Traders, 5D-6, Bungalow Plot  
Neelam Railway Road, NIT  
Faridabad-121 001  
Tel: 0129 4098 314, Fax: 0129 4098 221

#### Jaipur

Tata Steel - Tubes SBU,  
Marketing & Sales Division  
C/o. Vijayshree Properties Pvt. Ltd.  
C-84, Prithviraj Road, 'C' Scheme,  
Jaipur-302 001  
Tel: 0141 222 4725/651 8573  
Fax: 0141 5112906

#### Kanpur

Tata Steel - Tubes SBU,  
Marketing & Sales Division  
Navroz Building, M.G. Road,  
Kanpur-208 001  
Tel: 0512 235 3979/231 2870  
Fax: 0512 231 6631

#### Ludhiana

Tata Steel - Tubes SBU,  
Marketing & Sales Division  
B-30, 1858/1, Focal Point,  
Ludhiana-141 010  
Tel: 0161 267 0504/500 2742  
Fax: 0161 267 0504

#### Chandigarh

Tata Steel - Tubes SBU,  
Marketing & Sales Division  
SCO-16, 1st Floor, Sector - 26,  
Madhya Marg, Chandigarh - 160 019  
Tel: 0172 279 1047/279 0932

### East Zone

#### Kolkata

Tata Steel - Tubes SBU,  
Marketing & Sales Division  
Eastern Regional Sales Office  
52, J. L. Nehru Road, 2nd Floor,  
Kolkata-700 071  
Tel: 033 2282 4299/6550 8020/21/23/24  
Fax: 033 2282 4325

#### Bhubaneswar

Tata Steel - Tubes SBU,  
Marketing & Sales Division  
2-B, Fortune Towers, Chandrashekharpur,  
Bhubaneswar-751 023  
Tel: 0674 645 0611, Fax: 0674 2580968

#### Guwahati

Tata Steel - Tubes SBU,  
Marketing & Sales Division  
4th floor, Subham Velocity,  
Honuram Boro Path, Opp. Wallford  
G.S. Road, Guwahati - 781 005  
Tel: 0361 234 3962/3964/3965  
Fax: 0361 252 6582

#### Jamshedpur

Tata Steel - Tubes SBU,  
Marketing & Sales Division  
P.O. Burma Mines, Jamshedpur-831 007  
Tel: 0657 651 2063, Fax: 0657 227 938

#### Patna

Tata Steel - Tubes SBU,  
Marketing & Sales Division  
C/o. Jai Basukinath Traders Pvt. Ltd.  
House of Advocate Mr. K.P.Verma  
Boring Road, Patna-800 001  
Tel: 0612 223 2044, Fax: 0612 223 2044

#### Raipur

Tata Steel - Tubes SBU,  
Marketing & Sales Division  
Rajdhani Vihar, Block No. B, Flat No. 501,  
Kachna Road (Saddu), Near Bramha Kumari  
Ashram, Raipur-492 007  
Tel: 0771 645 2983, Fax: 0771 427 0588

#### Siliguri

Tata Steel - Tubes SBU,  
Marketing & Sales Division  
Sky Star Building, 6th Floor  
Sevoke Road, Siliguri-734 401  
Tel: 0353 253 0419, Fax: 0353 253 3527

### West Zone

#### Mumbai

Tata Steel - Tubes SBU,  
Marketing & Sales Division  
Orient House, 3rd Floor, Adi Marzban Path,  
Ballard Estate, Mumbai-400 038  
Tel: 022 6638 4512  
Fax: 022 2269 5963

#### Ahmedabad

Tata Steel - Tubes SBU,  
Marketing & Sales Division  
Premchand House Annexe  
High Court Way, 172/2, Ashram Road,  
Ahmedabad-380 009  
Tel: 079 5561 2608/09  
Fax: 079 5561 2604

#### Indore

Tata Steel - Tubes SBU,  
Marketing & Sales Division  
3rd Floor, NRK Business Park,  
B1 Scheme No. 54, A B Road  
Vijay Nagar, Indore - 452 010  
Tel: 0731 645 0691, Fax: 0731 253 5951

#### Nagpur

Tata Steel - Tubes SBU,  
Marketing & Sales Division  
Museum Road, Civil Lines  
Nagpur-440 001  
Tel: 0712 645 7677  
Fax: 0712 253 7078

#### Pune

Tata Steel - Tubes SBU,  
Marketing & Sales Division  
The Orion, Office No. 202B, 2nd Floor,  
5 Korigaon Park, Opp. St. Mira's College,  
Pune-411 001  
Tel: 020 6401 0604  
Fax: 020 6604 8828

### South Zone

#### Bangalore

Tata Steel - Tubes SBU,  
Marketing & Sales Division  
Jubilee Building, 2nd Floor,  
45, Museum Road,  
Bangalore-560 025  
Tel: 080 6695 0017  
Fax: 080 2532 5527

#### Chennai

Tata Steel - Tubes SBU,  
Marketing & Sales Division  
Chettinad Sigapi Achi Building  
18/3, 8th Floor, Rukmini Lakshmi Pathy Road  
Egmore, Chennai-600 008  
Tel: 044 669 60008, Fax: 044 282 69101

#### Secunderabad

Tata Steel - Tubes SBU,  
Marketing & Sales Division  
Surya Towers, 6th Floor,  
104/5, Sardar Patel Road,  
Secunderabad-500 003  
Tel: 040 6626 1020/30  
Fax: 040 2781 2418

#### Vijaywada

Tata Steel - Tubes SBU,  
Marketing & Sales Division  
Kasturi Towers-F1, Door No. 59-1-19A  
Ramachandra Nagar, Road No. 5,  
Vijaywada - 520 008  
Tel: 0866 308 4254

#### Kochi

Tata Steel - Tubes SBU,  
Marketing & Sales Division  
Santha Nivas, Door No. 41/3393  
Manaiikkapadi Lane, PRA No. 52  
Padivattom Edappally (Post)  
Kochi - 682 024  
Tel: 0484 280 5912

February 2013. This supercedes all previous editions.

Care has been taken to ensure that this information is accurate, but Tata Steel does not accept responsibility or liability for errors or information which is found to be misleading.

---

**TATA STEEL**

**Tata Steel Limited**

43 Jawaharlal Nehru Road, Kolkata 700 071

Tel: 91 33 2224 8106, 2224 8636, Fax: 91 33 2288 6996

Email: [tatastructura@tatasteel.com](mailto:tatastructura@tatasteel.com), Website: [www.tatastructura.com](http://www.tatastructura.com)

---

**Call our toll free Helpline: 1800 345 8282**